

*Backlit color display
Bluetooth® and
USB connectivity*

db® PRÜFTECHNIK

ROTALIGN® Ultra

The ultimate laser alignment system



**From the Inventors of
Laser Shaft Alignment**

An alignment powerhouse

ROTALIGN® Ultra is designed to make alignment tasks comprehensible and straightforward. It features a backlit colored screen that can be viewed in bright sunlight, concise navigation, an abundance of on-screen help, alphanumeric editing using the backlit keyboard, context menu operation and USB connectivity to PCs and other peripheral devices. Its heavy-duty rechargeable battery ensures a long operating time.

Sweep measure mode

The patented single laser technology and the built-in electronic inclinometer facilitate the continuous sweep measure mode. Measurement is accomplished by simply rotating the shafts from any position and in any direction.



Makes the difference

- Ultra-modern computer design
- Backlit color screen
- Intel XScale® 400 MHz CPU
- USB for peripheral devices: PC, printer
- Backlit keyboard
- Concise navigation
- Heavy-duty rechargeable battery
- Patented single laser-receiver technology
- Variety of measurement modes
- Machine train alignment – 14 machines
- Alignment results in 3 quick steps
- Soft foot expertise
- Thermal growth computation
- Rigid pre-assembled universal brackets
- Adjustable anti-slip hand grips
- Bluetooth™ communication
- Hard key data entry
- Clever word completion

Compact and handy

Universal connections

For sensor, charger and peripheral devices.

Hand grips

The adjustable loop (not shown) and the rubber grips ensure secure and comfortable handling of the computer.

Convenient stand

For suitable positioning of the computer during measurement.



Thrilling design and powerful performance

The modern design and intuitive user interface makes usage self-explanatory. All system functions can readily be accessed via the context and global menus. Depending on job at hand, five measurement modes are available.

Keyboard

The ergonomically designed keyboard consists of the navigation keys, data entry keys and function keys. It has a customary look and is conveniently positioned.



Overview screen

Displays entire machine train, the alignment condition, file name, current user, when measurement was last carried out and file modified, in one screen.

Color display screen

The 5.4 inch scratchproof transfective screen displays clear and colorful high quality life-like machine graphics.

LED indicators

The status of the laser position, alignment condition and battery is shown instantly via the two sets of integrated LEDs.

3 quick steps to results

Tackle any alignment situation using the proven 3-key strokes (Dimension-Measure-Results).

Speedy menu access

Menu operation

- Context menu with icons
- Global menu for all options
- Shortcut using numerals
- On-screen help

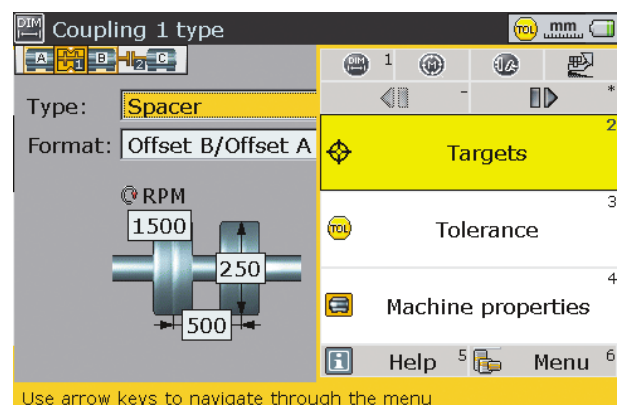

Program manager overview



Program Manager

- Resume file function
- Applications
- User defined templates
- Soft foot measurement
- Device configuration: User settings/ Device customization/ Predictive text entry/ Date and time/ Languages/ Units

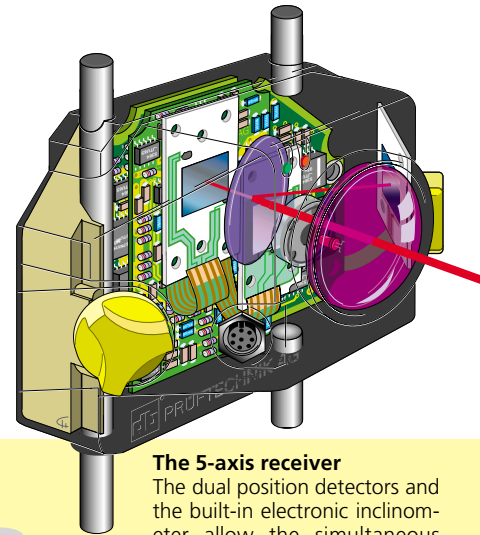

The 5-axis receiver

The dual position detectors and the built-in electronic inclinometer allow the simultaneous monitoring of the vertical and horizontal machine correction during MOVE.

Measurement flexibility

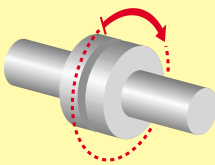

Continuous sweep mode

This quick and straightforward measurement mode is ideal for standard machines and requires a shaft rotation of as little as 60°.

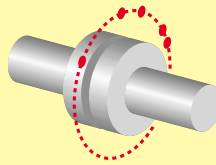

Multipoint mode

For shafts that are mounted on all types of bearings. Measurement requires 3 points or more at any position over 60° rotation.

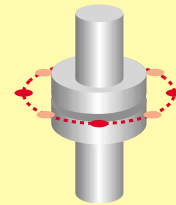

Static mode

This is the measurement mode for vertical alignment. Measurement requires 3 or more of the 8 available measurement positions.

Comprehensive and straightforward

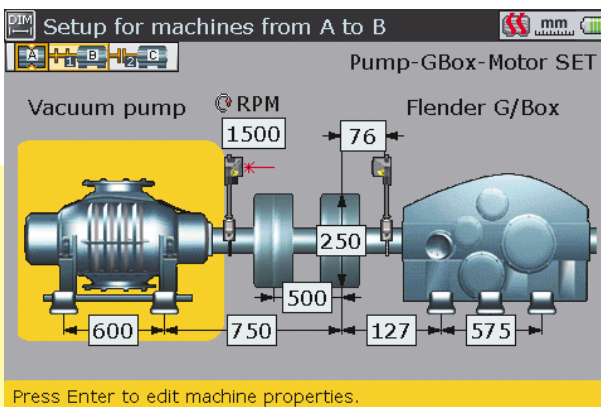

Machine set-up

- Horizontal and vertical alignment
- Train alignment with up to 14 machines
- Reusable files and templates
- Machine type
- Coupling type (short, cardan, spacer)
- Targets and thermal growth

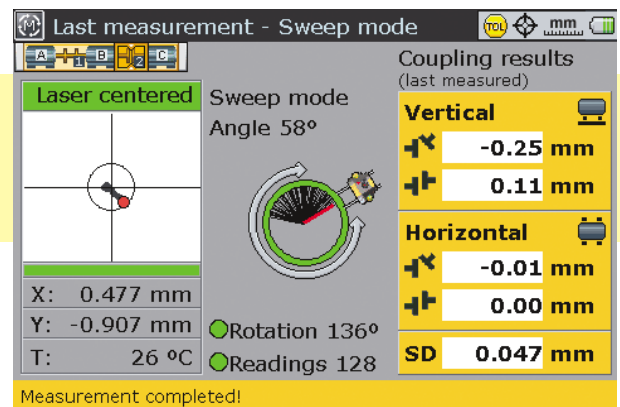

Taking measurements

- 5 measurement modes
- Coupling results displayed instantly
- Standard deviation
- Detector extend range
- Measurement table and history
- Editable measurement ellipse

PC software for job set-up, archival, reporting

The Alignment Explorer is the software for communication between a PC and current PRÜFTECHNIK alignment instruments. ROTALIGN Ultra READER and EDITOR are the Windows based software used with ROTALIGN Ultra. The READER (included with the system) supports one-way communication allowing measurement data to be transferred to a PC for viewing, printing and archiving in b/w. The EDITOR supports two-way communication allowing advance file preparation as well as editing, printing and archiving in color.

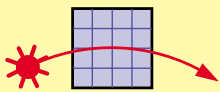
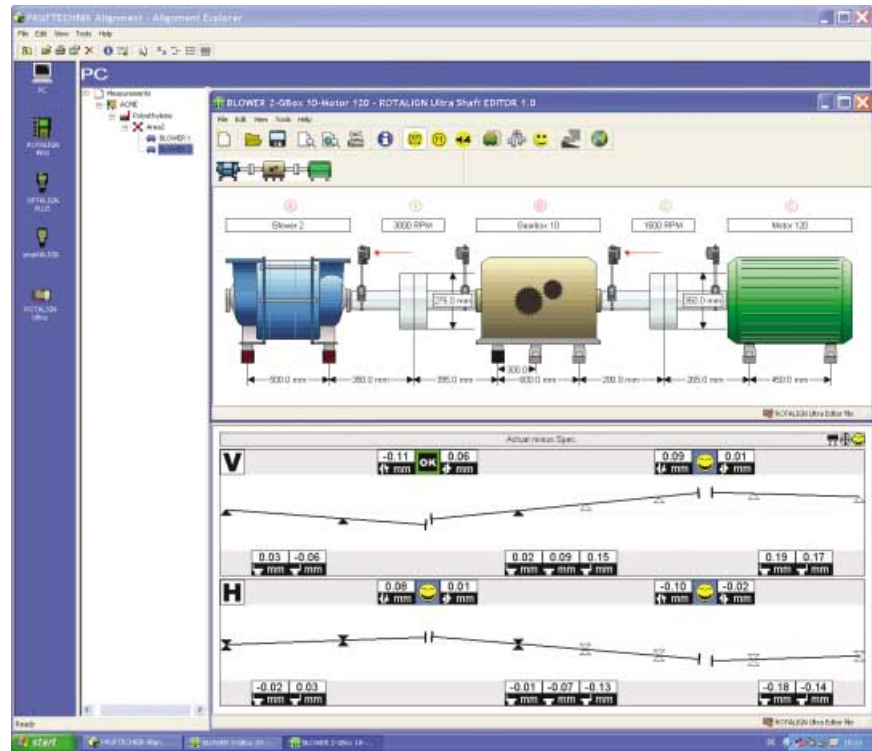

Pass mode

Uncoupled or non-rotatable shafts can be measured using this measurement mode.

Soft foot analysis

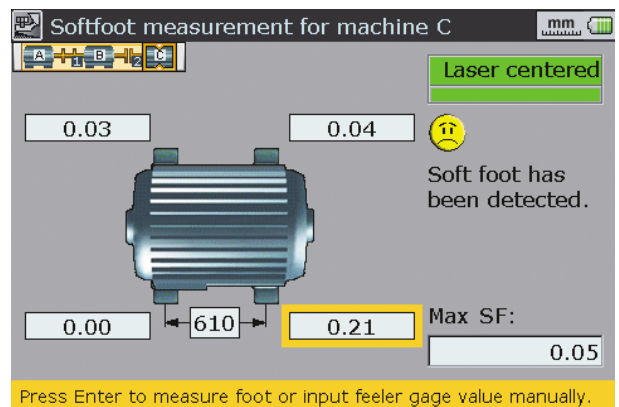
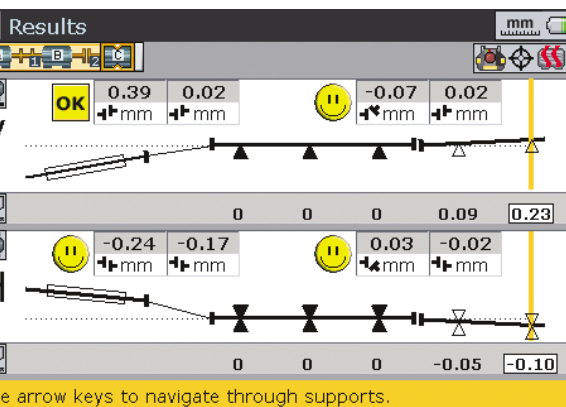

Alignment results

- Graphical display of feet and coupling results
- Live MOVE: V&H directions simultaneously
- Static feet (one pair or more)
- Dynamic tolerance/ User defined tolerance
- Tolerance envelope and smiley
- Alignment overview

Soft foot correction

- Measurement
- Diagnosis
- User defined soft foot tolerance

Technical data ROTALIGN® Ultra

Computer

CPU	Intel XScale® running at 400 MHz
Memory	64 MB RAM, 64 MB Internal Flash, 64 MB Compact Flash
Display	
Type	Transflective (sunlight-readable) backlit color graphic display
Resolution	1/2 VGA (480 x 320 pixels)
Dimensions	5.4 inch diagonal (118 mm x 80 mm)
Contrast	Adjustable
Illumination	Adjustable (0...70 cd/m ²)
Keyboard elements	Navigation cursor cross with three additional keys (up, clear and menu) Alphanumerical keyboard Three shortcut keys (hard keys for dimension, measure and results)
LED indicators	4 LEDs (blue, green, yellow, red) for laser status and alignment condition 2 LEDs (blue, green/red) for communication and battery status
Power supply	
Li-Ion rechargeable	(7.2 V / 6.0 Ah)
Operating time	> 25 hours typical use (25% measurement, 25% computation, 50% 'sleep' mode)
Charging time	< 6 hours
Charging display	2 LEDs (green/red)
Charging temp.	10 °C to 40 °C (50 °F to 104 °F)
'Sleep' mode	Adjustable
Weight	388 g (13.7 oz.)
Disposable batteries	(6x 1.5 V [IEC LR 14]) – optional
Operating time	> 12 hours typical use (25% measurement, 25% computation, 50% 'sleep' mode)
'Sleep mode'	Adjustable
Weight	Battery housing 553 g [19.5 oz.] (with batteries)
External interface	
USB host	Supports printing and external keyboard usage
USB slave	For PC communication
RS232 (serial)	For receiver
Wireless communication	Bluetooth™
Environmental protection	Shockproof, dustproof, water resistant, (IP 65)
Relative humidity	10% to 90%
Temperature range	
Operation	0 °C to 45 °C (32 °F to 115 °F)
Storage	-20 °C to 60 °C (-4 °F to 140 °F)
Dimensions	243 x 172 x 61 mm / 9.6 x 6.8 x 2.4 in.
Weight	1 kg (2.2 lb) without battery and stand
CE conformity (for cable lengths < 3 m (9.8 ft))	
General	EN 61326
Emission	EN 55022
Interference	EN 61000-4-2, -3, -4, -5, -6, -11

Laser

Laser	GaAlAs semiconductor laser
Wavelength	670 nm (typical)
Beam diameter	5 mm
Beam divergence	< 0.3 mrad
Beam power	< 1 mW
Laser safety class	Class 2; FDA 21CFR 1000 and 1040
Safety precautions	Do not look into laser beam.
Power supply	9V block battery, IEC 6LR61 (alkaline or lithium)
Operating time	80 hours continuous, depending upon battery type
Temperature range	0 °C - 50 °C (32 °F - 122 °F)
Weight	Approx. 165 g (5.8 oz.)

Receiver

Directions of 5-axis detector measurement	2 planes (4 displacement axes) 1 inclination 360° (angle to plumb) Unlimited, dynamically extendible
---	--

Measurement area	Approx. 160 mm (6 1/4 in)
Separation between measurement planes	Approx. 160 mm (6 1/4 in)
Resolution	1 µm (0.04 mil); angular 10 µRad
Error	< 2%
Error rotation angle	< 2°
Measurement rate	Approx. 20 Hz
Temperature range	0 °C - 60 °C (32 °F -140 °F)
Weight	Approx. 190 g (6.7 oz.)

Laser / Receiver

Max. measurement separation between laser and receiver	10 m (33 ft.)
Measurement stability	Ensured by temperature-stabilized light metal housing
Environmental protection	Shockproof, waterproof, dustproof (IP 67)
Protection from ambient light	Yes
Dimensions	Approx. 105 x 67 x 47 mm (4 1/8 x 2 5/8 x 1 7/8 in.)

Carrying case

Type	ABS, drop tested (2 m / 6 1/2 ft.) Case features 2 key locks and 1 combination lock.
Dimensions	565 x 375 x 193 mm (22.2 x 15 x 7.6 in.)
Weight, including all standard parts	Approx. 9 kg (19.8 lb.)



Further PRÜFTECHNIK applications



PERMALIGN® – continuous alignment monitoring

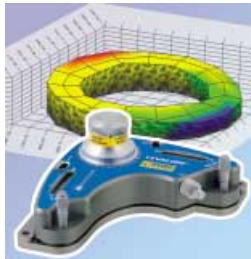

LEVALIGN® – measure surface flatness with precision



BORALIGN® & CENTRALIGN® – alignment of bores & turbines



Visit us at www.pruftechnik.com

Printed in Germany ALI 9.841.10.04.G
 ROTALIGN® is a registered trademark of PRÜFTECHNIK Dieter Busch AG. No copying or reproduction of this information, in any form whatsoever, may be undertaken without express written permission of PRÜFTECHNIK AG. The information contained in this leaflet is subject to change without further notice due to the PRÜFTECHNIK policy of continuous product development. PRÜFTECHNIK products are the subject of patents granted or pending throughout the world.
 © Copyright 2004 by PRÜFTECHNIK AG.

PRÜFTECHNIK Alignment Systems
 Oskar-Messter-Straße 15
 D-85737 Ismaning, Germany
www.pruftechnik.com
 Phone: +49 (0)89 99 61 60
 Fax: +49 (0)89 99 61 61 00
 eMail: info@pruftechnik.com

From the inventors of laser shaft alignment